

TEAM® Industrial Services

InsertValve™

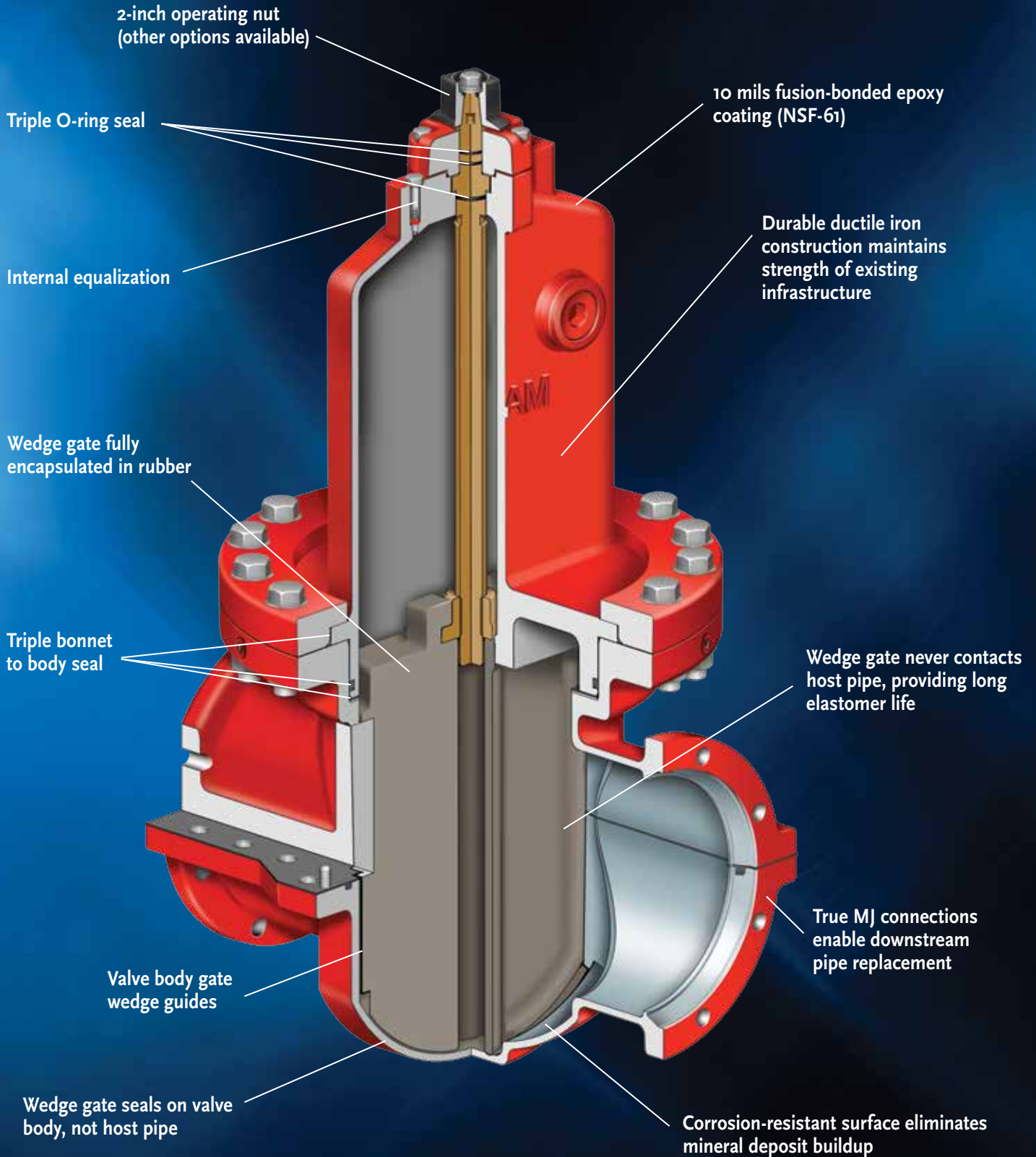

The Team InsertValve™ is a fully functioning, resilient wedge gate valve with a rated working pressure of 250 psig. The valve fully closes, and it provides a clear, unobstructed waterway under full rated working pressure. The valve's superior design and engineering characteristics provide many distinct operational benefits.



VALUE, RELIABILITY, PERFORMANCE

Team's patented InsertValve delivers value, reliability and performance second to none in a wide range of pipeline industries and applications, including tapping, line stopping, valve insertion and capital improvement connection. This field-proven valve installs under pressure, eliminating the need for costly system disruptions and product waste.

A Real Valve, Inserted Under Full Line Pressure

- Meets ANSI/AWWA C515 material standards
- Installs on a full range of pipe sizes and types
- Valve permanently restrained to the pipe to maintain pipe integrity
- Provides instant isolation zones for security and peace of mind
- Eliminates backflow contamination, purging and bac-t hits
- Allows for removal/replacement of downstream pipe at any time
- Enables in-line, under pressure repair of all moving parts
- Ensures clean valve seat after installation process



An InsertValve installation under full line pressure.



The InsertValve can be installed in any orientation on any type of pipe material.



InsertValves on AC pipe for main control and hydrant replacement preventing asbestos fibers becoming airborne.



An InsertValve with position indicator plate. Valve can be fitted with gear or handwheel operators.

AN INSIDE LOOK AT TEAM'S INSERTVALVE

The Team InsertValve is available in 4-inch thru 12-inch sizes with handwheel and gear operators. Valves and operators have been tested and proven to deliver reliable service at pressures ranging from vacuum to 250 psig and temperatures to 180°F (higher temperature options available). Unlike some valves, the InsertValve is designed to handle full water and wastewater system hydraulic forces that are typically applied. And, these rugged valves can be oriented in virtually any position on any type of pipe, including ductile iron, cast iron, steel, PVC and AC.

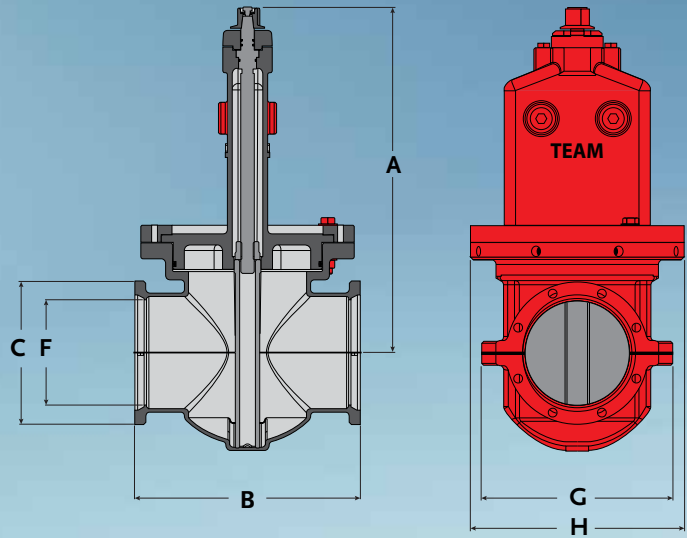

Nominal Size	4"	6"	8"	10"	12"
A	21" (533)	23 1/2" (597)	28 1/4" (718)	36" (914)	41" (1041)
B	16" (406)	18" (457)	20" (508)	25" (635)	30" (762)
C	9 1/2" (241)	11 1/4" (286)	13 1/2" (343)	15 3/4" (400)	18" (457)
F	4.5-5.26 (114-134)	6.63-7.2 (168-183)	8.63-9.3 (219-236)	10.75-11.3 (273-287)	12.75-13.42 (324-341)
G	13 1/4" (337)	15 1/4" (387)	16" (406)	21" (533)	24" (610)
H	13 1/2" (343)	16" (406)	19" (483)	23 1/2" (597)	27 1/2" (699)



Typical pipe with internal obstructions. InsertValve gate sits on the valve body and not the host pipe.



An under-pressure look of clean valve seat.

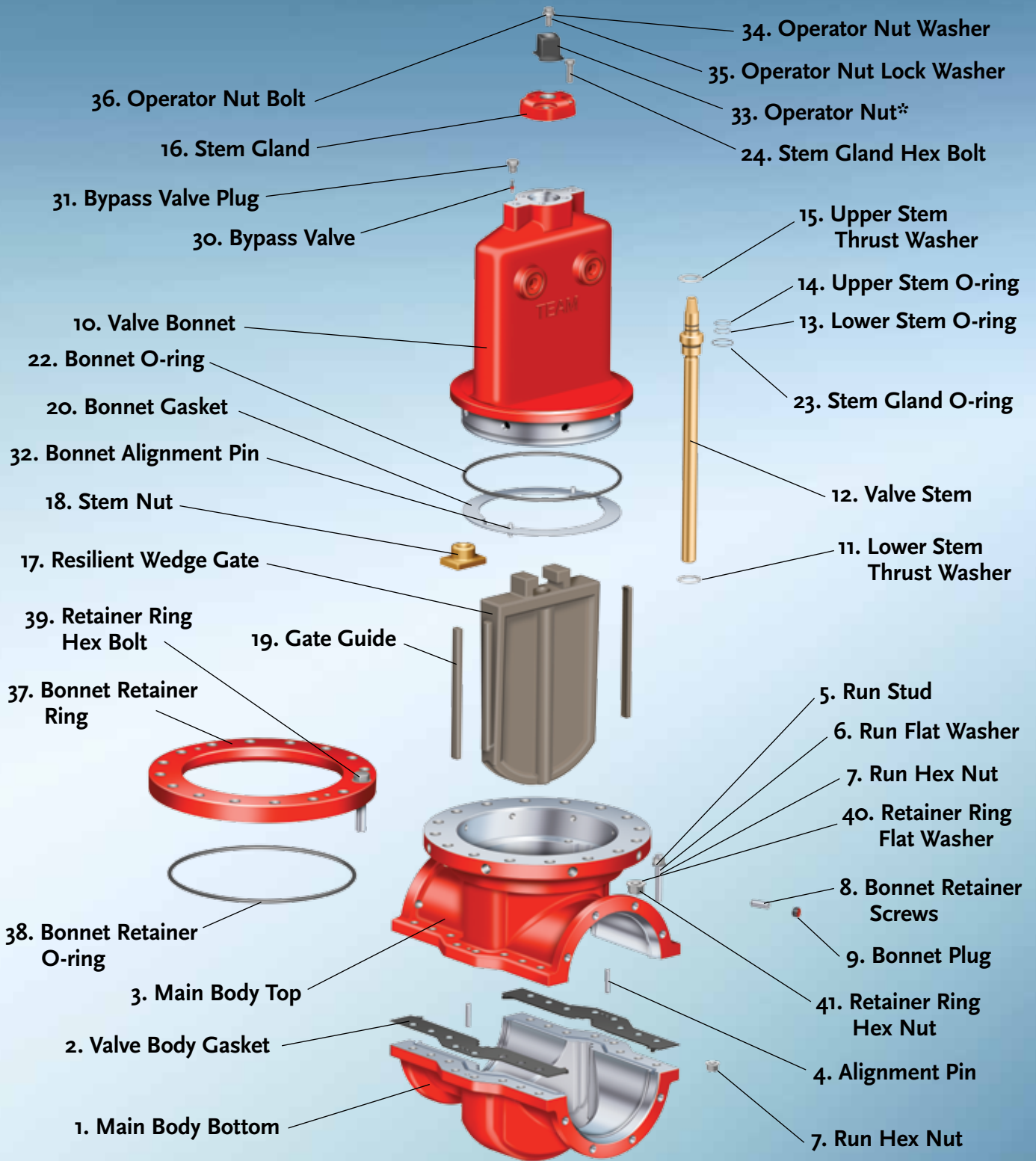

*The Team InsertValve can be equipped with various operators, including gear and handwheel, as well as a post indicator.

FAST, EASY INSTALLATION

Team offers professional installation by trained and certified technicians. Valves and complete installation packages are also sold for successful third-party

installation. Either way, you get a valve that meets or exceeds all recognized industry requirements. Team's InsertValve installs in three easy steps.

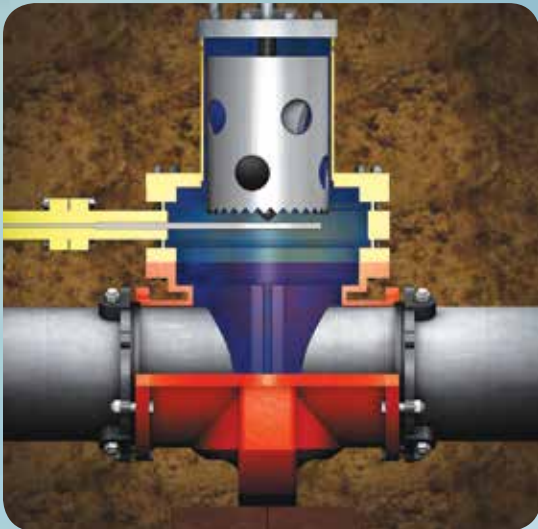

Step 1
Tapping machine removes complete section of pipe.

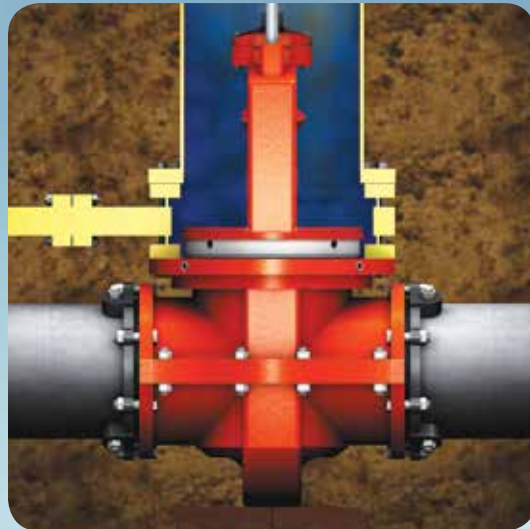

Step 2
Insert bonnet into the valve body.

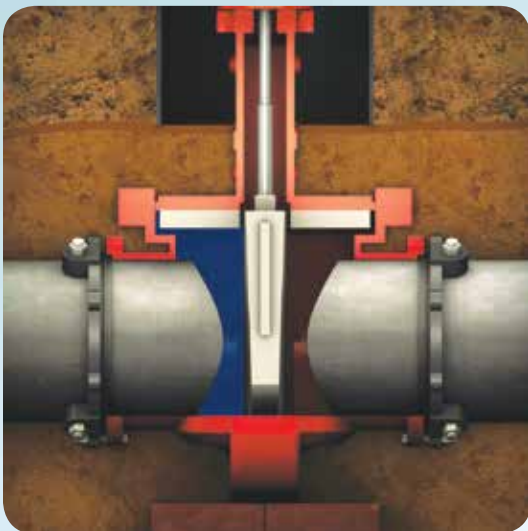

Step 3
Valve is now operational.

The Team InsertValve, with its permanent, resilient seat, has just been installed into the piping infrastructure without interruption or loss of pressure. A valve box is installed and the valve is ready for operation.

To view animation of the Team InsertValve installation process, simply scan the QR Code below with your SmartPhone.



CAPITAL IMPROVEMENT CONNECTION™

Specify the Team Capital Improvement Connection (CIC) for your next capital improvement project. Team's CIC provides valve control today, and pipe replacement tomorrow, even upsizing of the pipe if

necessary. This is made possible by the unique design of its integral mechanical joint connection coupled with the fact that the host pipe is not a permanent part of the CIC.

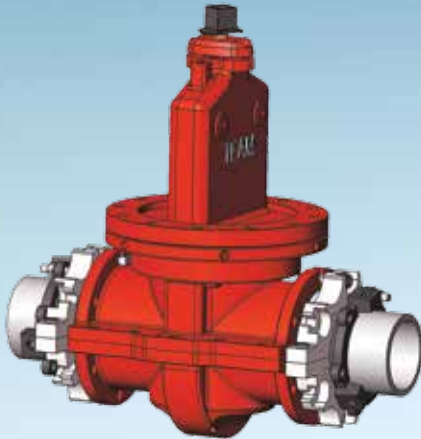

Install the InsertValve size of your choice.

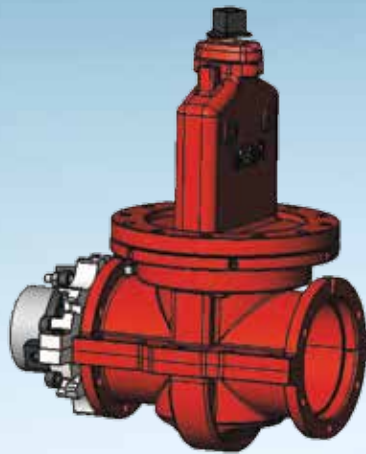

Restrain the valve and remove the downstream pipe.

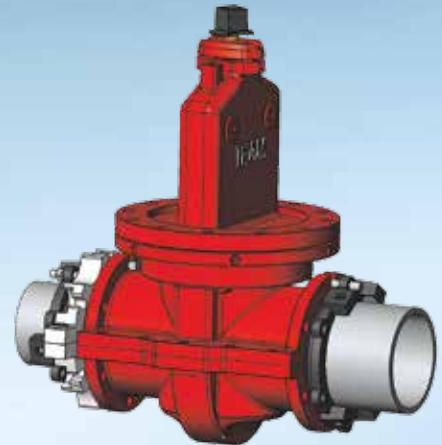

Install new downstream pipe.

LINE STOPPING

After you've finished the capital improvement project, you can either leave the bonnet or remove the bonnet.

The choice is yours. The infrastructure is not compromised with Team's ductile iron MJ line stop fitting.



Low-profile bonnet used as line stop.



Internal equalization completion plug installed.



Blind flange installed.

Corporate headquarters:

200 Hermann Drive

Alvin, Texas 77511

Phone: 800-662-8326

Phone: 281-331-6154

Fax: 281-331-4107

For more information, call:

